

CubeSat Kit User Manual

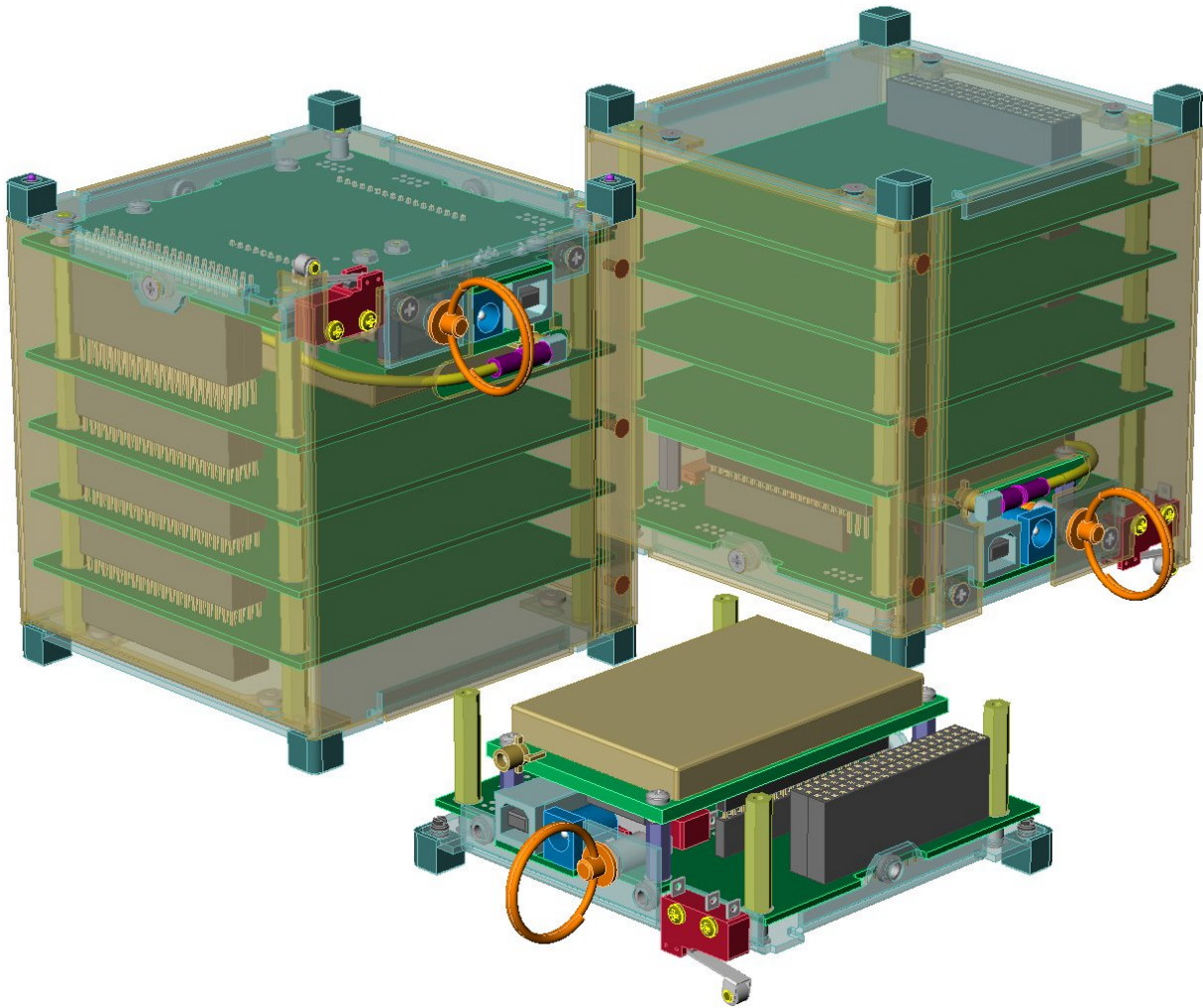

© 2000-2005 Pumpkin, Inc. All rights reserved.
Specifications subject to change without notice.

Introduction

Pumpkin, Inc.'s CubeSat Kit is a commercial off-the shelf (COTS) kit designed to radically reduce the time and effort required to build a functional satellite conforming to the current CubeSat (<http://www.cubesat.info/>) specification.

The CubeSat kit fully adheres to the CubeSat specification's electrical and mechanical requirements. The included FM430 Flight Module sports an ultra-low-power single-chip RISC microcontroller (<100mW) and a complete 80-pin system bus for expansion. The Flight MCU can be pre-programmed with Pumpkin's Salvo Real-Time Operating System (RTOS) to facilitate rapid software development. COTS or custom transceivers module can be installed on the Flight Module without any modifications to the CubeSat Kit. In addition to the Flight Module, the 10x10x10cm CubeSat Kit can accommodate up to 4 (four) 8- or 16-bit PC/104-compliant modules, up to 5 (five) user modules,¹ or a combination of both.

Information

All CubeSat Kit information – including this manual – is available online at <http://www.cubesatkit.com/>.

Information for CubeSat Kit customers is available in the [Customer Download Area](#). This area includes CubeSat Kit software, schematics, specification pages, etc.

Background

The goal of the worldwide CubeSat project is to deliver 1kg payloads in a 10cm cubed package into low earth orbit at low cost. Groups around the world are developing their own CubeSats.

The CubeSat Kit evolved from a hardware and software co-design process. By combining a low-power, single-chip microcontroller with a weight-conscious mechanical design, the CubeSat Kit's available payload can be maximized.

¹ User modules in Slot 5 have additional height restrictions.

Motivation

Pumpkin partnered with the mechanical design firm design MASSIF to create the CubeSat Kit. Pumpkin is very excited to be involved in a space-related project, and are eager to see the CubeSat Kit deployed into space.

Additionally, Pumpkin is eager to promote Salvo as the premier RTOS solution for embedded, single-chip microcontrollers. Salvo is a perfect fit for the CubeSat's microcontroller (i.e. its "brains"). Salvo fits in the smallest and lowest-power microcontrollers, thus keeping the electronics well within the tight mass and power constraints placed on each CubeSat. Also, programming a CubeSat in C with an RTOS should substantially shorten development times compared to other programming methodologies.

The CubeSat Kit

Each CubeSat Kit contains:

- A CubeSat structure (base plate assembly, chassis and cover plate assembly)
- Flight Module with Flight MCU
- Development Board with Flight MCU header board and prototyping area
- External benchtop +5V power supply
- Debugging and programming interface
- Miscellaneous parts (e.g. spacers, switches, USB cable, etc.)
- Pumpkin's Salvo RTOS
- Documentation (engineering drawings, schematics, etc.)

As a CubeSat Kit user, it's up to you to supply:

- Power source (e.g. batteries and/or solar cells)
- Custom user PCBs, if required
- Communications equipment (e.g. radio, antenna)
- Additional PCBs for your own electronics, if required
- Additional mechanical, electrical and other components
- A compiler / IDE for developing the software for the Flight MCU

To transform a CubeSat Kit into a working CubeSat satellite, you'll need to:

- Decide on the internal configuration of your CubeSat
- Solder a few connectors and wires
- Design and implement a power system (e.g. solar cells, batteries, regulators, etc.) tailored to your CubeSat
- Implement a communications system (radio, antenna) for your CubeSat
- Design and implement any other electronics your CubeSat requires
- Integrate all of these items (your "payload") into your CubeSat
- Write software to interface to and control the CubeSat

Getting Started

Development Board

Flight MCU

Unpack the following CubeSat Kit items:

- Development Board
- Benchtop +5V power supply²
- USB cable

Note Several revisions (Rev A, Rev B, etc.) of the CubeSat Kit hardware exist. In general, each new revision is a superset of the previous one. Certain features will only be present in later revisions.

Verify that the jumpers on the Development Board are set to their default values for your Flight MCU:

² Supplied without a power cord to customers outside the USA. Accepts IEC-standard power cords.

Jumper	Setting	✓
JP1	ON	
JP2	ON	
JP3	ON	
JP4	ON	
JP5	ON	
JP6	OFF	
JP7	ON	
JP8	ON	
JP9	ON	
JP10	ON	
JP11	OFF	
JP12	1-3, 2-4	
JP13	5-6	
JP14	2-3	
JP15	ON	
JP16	ON	

Table 1: Default Jumper Settings for Development Board for MSP430 Flight MCU

With the Benchtop +5V power supply's power cord connected to 100-240VAC, plug its output into J1 and verify the following voltages:³

WARNING Primary bus power to the CubeSat Kit's circuitry is +5V. Voltages in excess of +5.5V may irreparably damage CubeSat Kit circuitry connected directly to the +5V bus (e.g. transceivers). Exercise extreme care when plugging dc power into the CubeSat Kit.

Signal	Location	Value	✓
+5V	TP9	+5V	
VCC	TP12	+3.3V	
VCC MCU	TP20	+3.3V	
VCC_232	TP21	+3.3V	
V+_232	TP19	> +5V	
V-_232	TP22	< -5V	
+5V_SW	TP10	0V	
-RST/NMI	TP8	+3.3V	

Table 2: Startup Voltages for Development Board for MSP430 Flight MCU

The Flight MCUs are preprogrammed with demo/test code for the Pumpkin CubeSat Kit. The LED on the Flight MCU header board should start blinking, indicating that the test/demo code in the Flight MCU is running correctly.

³ There are several GND test points scattered across the Development Board.

Debug / Programming Interface

Connect the Programming / Debug Adapter to the JTAG port on the Flight MCU header board, and to your PC. Start your development software and verify that you can communicate with the Flight MCU. Verify that the manual reset switch (sw3) works properly.

USB Interface

Download Pumpkin's CubeSat Kit USB drivers from the CubeSat Kit website at (<http://www.cubesatkit.com/driver/usb/>). Follow the instructions in Pumpkin Application Note [AN-27](#) to install the Pumpkin CubeSat Kit USB drivers on your PC or Mac.

Note The CubeSat Kit requires these Pumpkin USB drivers. No other drivers will work properly.

Remove +5V power from the Development Board. Connect the USB cable between the USB module and your PC. Your PC should now recognize the USB device – follow the FTDI instructions on completing the driver installation. Verify the following:

Signal	Location	Value	✓
+5V_USB	TP11	+5V	
VCC_IO	TP13	+3.3V	
-RST_USB	H7.3	+3.3V	

Table 3: Voltages for Bus-powered USB Module on Development Board for MSP430 Flight MCU

Open a terminal application (e.g. Windows Hyperterminal), connect to the USB port's emulated Com port (usually COM3 or COM4), and configure the communications port for 9600 baud, 8 data bits, 1 stop bit, and no handshaking. You should see a terminal window with debugging output in text form being sent by the Flight MCU via the USB interface.

Note The USB serial port is active even with the Development Board off because the USB-to-serial interface is bus-powered, i.e. powered from the USB bus.

Reapply +5V power to the Development Board.

MHX Transceiver

Remove +5V power from the Development Board. Install the MHX transceiver, observing the correct orientation. Reapply +5V power. After a few seconds, the FM430 test/demo program will enable power to the MHX transceiver, which will then cycle its `RSSI[3..0]` LEDs as part of its power-up sequence.

Additional Features

The Development Board includes additional circuitry that is particularly useful when deriving power from other sources, and for measuring current draw. Refer to *Additional Features of the Development Board* for more details.

Configuring the CubeSat Kit

User Modules

User-provided Printed Circuit Board (PCB) modules are of the same overall size and have the same mounting holes as PC/104 modules. Additionally, these modules must locate the CubeSat System Bus connectors properly so as to be able to interface to the Flight Module via the CubeSat Kit Bus.

CubeSat Kit Slots

The CubeSat Kit is designed to accept user or PC/104 modules in addition to the Flight Module. The locations of the modules are referred to as Slot 0 through Slot 5, where Slot 0 is at the Launch Switch end of the CubeSat. Modules are mounted in a stack of PCBs, PC/104-style, and connectors via threaded standoffs or a combination of threaded rods and spacers. The stack normally begins with the Flight Module in Slot 0 just above the CubeSat Kit's Base Plate, and ends with the final slot's standoffs being attached to the CubeSat Kit body just below the Cover Plate.

The smallish dimensions of the CubeSat introduce certain limits on the modules when fitted in certain Slots. The constraints that deviate from the PC/104 specification are listed in Table 4, and are all mechanical in nature.

Slot	Accepts	Height	Constraints on Module
0	Flight Module	15mm or 25mm	Only the Flight Module can be mounted in Slot 0. Cannot accept MHX transceiver if Slot 1 is occupied by a PC/104 module.
1	User module or PC/104 module	15mm or 25mm	User module must provide powered PC/104 connectors or include PC/104 stack-through connectors if PC/104 modules are used in Slots 2-5. Can be occupied by a PC/104 module if connectivity between user modules and the Flight Module is not required. When MHX transceiver is fitted on Flight Module, component keep-out area on underside of module must be observed.
2	User module or PC/104 module	15mm or 25mm	
3	User module or PC/104 module	15mm or 25mm	
4	User module or PC/104 module	13mm, 15mm or 23mm	
5	User module (low-profile)	6mm	Greatly reduced topside component height. Only available when 15mm spacers are used between Slot 0 and Slot 1.

Table 4: Slot Descriptions – Mechanical Compatibility

Inter-Slot Spacing

Since PC/104 connectors are used, the normal distance between adjacent modules is 15mm (0.6"), just like PC/104. It is also possible to use alternate connectors to yield 25mm between slots.

There are a few special cases: Slot 0, Slot 4 and Slot 5.

Slot 0 Spacing

When an MHX transceiver or other radio module of similar proportions is fitted to the Flight Module, 25mm (instead of 15mm) standoffs must be used between Slot 0 and Slot 1.

Slot4 Spacing

When Slot 4 is occupied by the last module, its standoff will be approximately either 13 or 23mm in length, dependent on the Slot

0 standoff length. If a module is fitted in Slot 5, Slot 4 will use the standard 15mm standoff.

Slot5 Spacing

When Slot 5 is the last slot occupied by a module, its standoff will be approximately 6mm in length.

Final Standoff Heights

The approximate nature of the standoffs used for Slots 4 and 5 is due to tolerance build-up and imperial / metric size differences. Users should measure the exact required height using a caliper on their assembled CubeSat kit, and fabricate the necessary spacer by shortening an existing, longer one.

Configuration Examples

With the CubeSat Kit, users can configure their CubeSats in a variety of ways. Examples 1-7 below employ a conventional board stacking topology, which places user modules and/or PC/104 modules above the Flight module in Slots numbered 0 through 5. The CubeSat System Bus and the PC/104 bus are (where applicable) connected from one module to another via PC/104-style stackthrough connectors. The CubeSat System Bus connectors are on the opposite side of the CubeSat from the PC/104 connectors. The CubeSat System Bus connectors (2x20 pins each) are identical to the PC/104 standard's J2 (16-bit extension) connector.

Note The examples below are for a "1U" CubeSat (10x10x10 cm). Naturally, the numbers of user modules and PC/104 modules can be increased in "2U" (10x10x20 cm) and "3U" (10x10x30 cm) CubeSats.

1. Flight Module + MHX Transceiver + 1 User Module

This configuration uses the Flight Module, with an MHX transceiver mounted to it, and a user module that interfaces the user's payload with the Flight MCU on the Flight Module. The CubeSat's operating software resides in the Flight MCU. The Flight module is connected to the user module via the two CubeSat System Bus connectors. For this configuration, 25mm standoffs are

used between the Flight MCU (Slot 0) and the user module (Slot 1) to make room for the MHX transceiver.

2. Flight Module + MHX Transceiver + 4 User Modules

In this configuration, the CubeSat System Bus is extended through multiple user modules. To make room for the MHX transceiver, 25mm standoffs are used between the Flight Module in Slot 0 and the user module in Slot 1. 15mm standoffs are used between adjacent user modules.

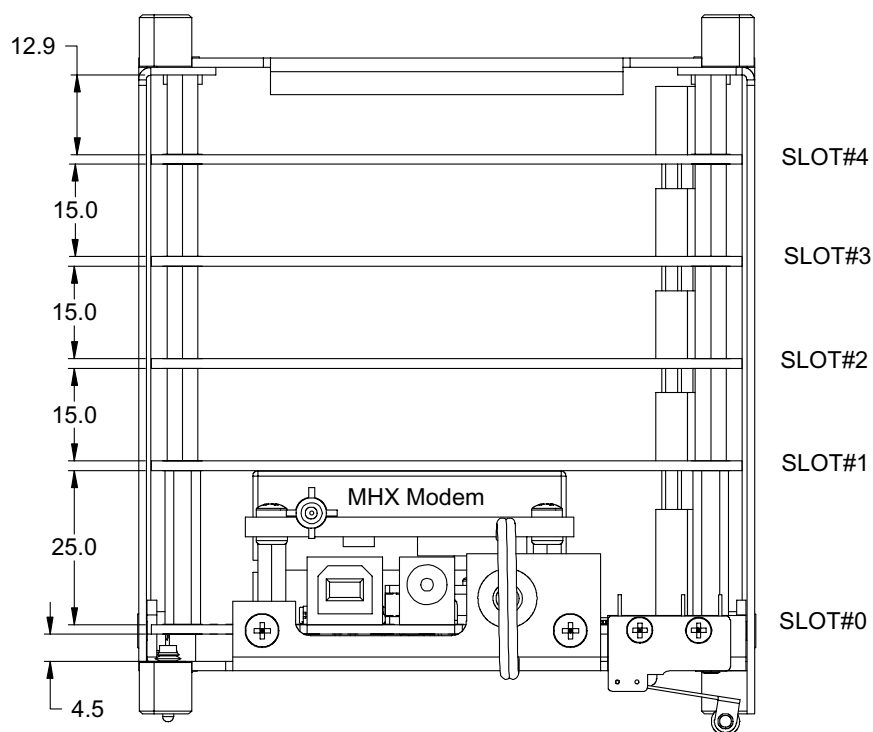

Figure 1: Flight Module + MHX Transceiver + 4 User Modules

3. Flight Module + MHX Transceiver + User Module + 3 PC/104 Modules

In this configuration, with the user module between the Flight Module and up to 2 PC/104 modules, the user module is likely to implement a bridge between the CubeSat System Bus and the PC/104 bus. The bridge must, at a minimum, connect the +5V and GND signals of the CubeSat System Bus to those of the PC/104 bus. A configuration like this may or may not have an additional processor on the PC/104 modules.

4. Flight Module + 2 User Modules + 2 PC/104 Modules

In this configuration, two user modules are located between the Flight Module and the PC/104 modules. The lower (Slot 1) user module can interface solely to the Flight Module via the CubeSat System Bus, whereas the upper (Slot 2) user module is likely to implement a bridge between the CubeSat System Bus and the PC/104 bus. The bridge must, at a minimum, connect the +5V and GND signals of the CubeSat System Bus to those of the PC/104 bus.

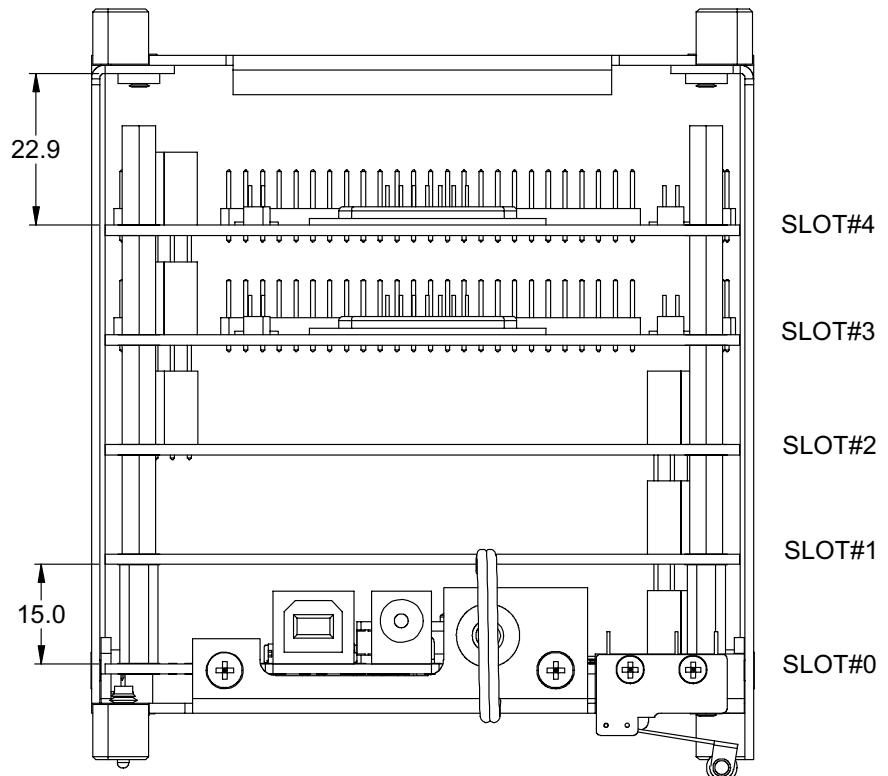

Figure 2: Flight Module + 2 User Modules + 2 PC/104 Modules

5. Flight Module + 4 PC/104 Modules

This configuration lacks a direct means of interfacing the Flight Module's Flight MCU with the PC/104 modules. However, it is conceivable that the two might be connected by a wire harness between one or more PC/104 modules and the CubeSat System Bus connectors on the Flight Module.

Note Due to clearance issues, a PC/104 module cannot occupy Slot 1 if the MHX transceiver is fitted to the Flight Module.

6. Flight Module + 4 PC/104 Modules + 1 Low-Profile User Module

This configuration lacks a direct means of interfacing the Flight Module's Flight MCU with the PC/104 modules. However, it is conceivable that the two might be connected by a wire harness between one or more PC/104 modules and the PCB pads for the CubeSat System Bus connectors.

Note Due to clearance issues, a PC/104 module cannot occupy Slot 1 if the MHX transceiver is fitted to the Flight Module.

7. Flight Module + 4 User Modules + 1 Low-Profile User Module

This configuration eschews the transceiver on the Flight MCU in favor of a user-supplied transceiver on one of the user modules. Choosing not to use the MHX transceiver reduces the spacing between Slot 0 and Slot 1 to only 15mm, and enables the fitting of an additional module in Slot 5.

Note The user module in Slot 5 has additional constraints on its component height. Stackthrough-style connectors cannot be used on this module.

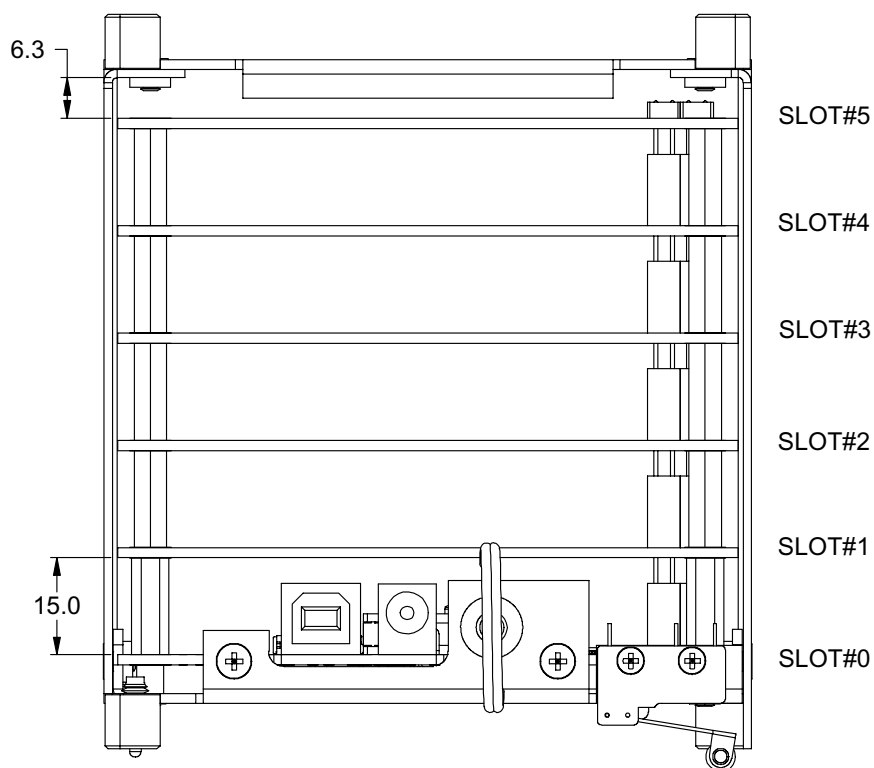

Figure 3: Flight Module + 4 User Modules + 1 Low-Profile User Module

8. Non-stacking Topology

An alternative board interconnect scheme seen in some CubeSats designs is to keep the various PCBs on the inside surfaces of the CubeSat, freeing the central volume for payload. This can also be achieved with the CubeSat kit. It requires that a user module interface to the Flight Module by plugging into the Flight Module at a right angle using alternate connectors.⁴

Overview of Examples

Table 5 summarizes the configuration examples listed above.

⁴ This may require a custom, small intermediate PCB between the Flight Module and the user module in order to locate the user module against the CubeSat's inner skin.

#	Slots	MHX Xcvr OK?	Standoffs	Connectors	
				CubeSat System Bus	PC/104 Bus
1	0: Flight MCU 1: user module 2: payload 3: payload 4: payload 5: n/a	yes	0: 25mm 1: -- 2: -- 3: -- 4: -- 5: n/a	0: NST-T 1: ST-N 2: -- 3: -- 4: -- 5: --	0: -- 1: -- 2: -- 3: -- 4: -- 5: --
2	0: Flight MCU 1: user module 2: user module 3: user module 4: user module 5: n/a	yes	0: 25mm 1: 15mm 2: 15mm 3: 15mm 4: 13mm 5: n/a	0: NST-T 1: ST-N 2: ST-N 3: ST-N 4: ST-N 5: --	0: -- 1: -- 2: -- 3: -- 4: -- 5: --
3	0: Flight MCU 1: user module 2: PC/104 module 3: PC/104 module 4: PC/104 module 5: n/a	yes	0: 25mm 1: 15mm 2: 15mm 3: 15mm 4: 13mm 5: n/a	0: NST-T 1: ST-N 2: -- 3: -- 4: -- 5: --	0: -- 1: NST-N 2: ST-N 3: ST-N 4: ST-N 5: --
4	0: Flight MCU 1: user module 2: user module 3: PC/104 module 4: PC/104 module 5: n/a	no	0: 15mm 1: 15mm 2: 15mm 3: 15mm 4: 23mm 5: n/a	0: NST-T 1: ST-N 2: ST-N 3: -- 4: -- 5: --	0: -- 1: -- 2: ST-N 3: ST-N 4: ST-N 5: --
5	0: Flight MCU 1: PC/104 module 2: PC/104 module 3: PC/104 module 4: PC/104 module 5: n/a	no	0: 25mm 1: 15mm 2: 15mm 3: 15mm 4: 13mm 5: n/a	0: -- 1: -- 2: -- 3: -- 4: -- 5: --	0: NST-T 1: ST-N 2: ST-N 3: ST-N 4: ST-N 5: --
6	0: Flight MCU 1: PC/104 module 2: PC/104 module 3: PC/104 module 4: PC/104 module 5: user module (LP)	no	0: 15mm 1: 15mm 2: 15mm 3: 15mm 4: 15mm 5: 6mm	0: -- 1: -- 2: -- 3: -- 4: -- 5: --	0: NST-N 1: ST-N 2: ST-N 3: ST-N 4: ST-N 5: END
7	0: Flight MCU 1: user module 2: user module 3: user module 4: user module 5: user module (LP)	yes	0: 15mm 1: 15mm 2: 15mm 3: 15mm 4: 15mm 5: 6mm	0: NST-N 1: ST-N 2: ST-N 3: ST-N 4: ST-N 5: END	0: -- 1: -- 2: -- 3: -- 4: -- 5: --
8	0: Flight MCU 1-5: n/a	yes	0: -- 1-5: n/a	0: user 1-5: n/a	0: -- 1-5: n/a

END: non-stackthrough, minimal protruding height above module's PCB surface (surface-mount recommended)
 NST-N: non-stackthrough, normal height (for 15mm stacking)
 NST-T: non-stackthrough, tall height (for 25mm stacking)
 ST-N: stackthrough, normal height (for 15mm stacking)

Table 5: Summary of Example CubeSat Kit Configurations

The topology of the configuration you choose for your CubeSat Kit affects which connectors should be installed on the Development Board and Flight Module. Each CubeSat kit is supplied with a complete set of connectors for topologies that locate Slot 1 25mm above Slot 0. If your configuration requires Slot 1 to be only 15mm above Slot 0, or if you will be using a non-stacking topology, then you will need to source your own connectors instead of using the supplied ones. PC/104 modules are already supplied with the correct stackthrough connectors.

USB

The CubeSat kit Development Board and Flight Module include a Universal Serial Bus (USB) interface, using the FTDI (<http://www.ftdichip.com/>) FT232BM serial-to-USB interface chip. The Flight MCU can communicate bidirectionally with a *host* (usually a PC) using one of its on-board USARTs. Hardware and software handshaking are supported.

Flight MCU Interface

The FT232BM interfaces to the Flight MCU via six I/O lines:

FT232BM Pin Name	Function	Direction	Bit-Bang Assignment
TXD	serial data	host → MCU	Data 0, → MCU
RXD	serial data	MCU → host	Data 1, → host
-RTS	handshake	host → MCU	Data 2, → MCU
-CTS	handshake	MCU → host	Data 3, → host
-DTR	handshake	host → MCU	Data 4, → MCU
-DSR	--	--	n/a
-DCD	--	--	n/a
-RI	handshake	MCU → host	Data 7, → host
-RST	reset	MCU → FT232BM	--
-PWE	status	FT232BM → MCU	--
TXN	--	--	--

Table 6: USB-to-serial Converter Pin Assignments

Note The USB interface is shared with the MHX (transceiver). Therefore at any time, only one can be connected to the Flight MCU's USART.

USB Drivers

The CubeSat Kit requires the installation of Pumpkin CubeSat Kit USB drivers (Win 98 / ME / 2000 / XP). The drivers are modified versions of the standard FTDI Virtual COM Port (VCP) drivers. Download Pumpkin's CubeSat Kit USB drivers from the CubeSat Kit website at (<http://www.cubesatkit.com/driver/usb/>). Follow the instructions in Pumpkin Application Note [AN-27](#) to install the Pumpkin CubeSat Kit USB drivers on your PC or Mac.

Powering the CubeSat via USB

The FT232BM is configured as a *bus-powered* (i.e. USB-powered) device on the Development Board and Flight Module. The USB specification permits bus-powered devices to draw 100mA at +5V from all USB hosts, and up to 500mA at +5V from powered hosts. Therefore⁵ the CubeSat Kit *can be powered from the USB port alone*. This is useful for development purposes, and also to communicate with a fully assembled CubeSat Kit without having to apply additional external power.

⁵ With proper configuration of the FT232BM configuration EEPROM. The CubeSat Kit can draw a maximum of 500mA (at +5V) from the USB interface. It is up to the CubeSat Kit user to control the CubeSat Kit's power consumption when powered directly from the USB interface.

Development Board Jumpers

JP1

Jumper JP1 connects the output of the +5V LDO regulator to the +5V bus. The regulator can be isolated from the circuitry via JP1.

ON

When connected / ON, current flows from the +5V LDO regulator to the +5V bus.

OFF

When disconnect / OFF, the +5V LDO regulator is isolated from the +5V bus.

Note The quiescent draw of the +5V LDO regulator is approximately 10mA. This current is also drawn when +5V is present on the regulator output without any voltage on the regulator input. Therefore it is *imperative* to disconnect JP1 when measuring overall system current draw.

JP2

Jumper JP2 connects the 2.1mm external power connector to the +5V bus.

ON

When connected / ON, J1 is connected to the +5V bus.

OFF

When disconnect / OFF, the + / center pin of J1 is isolated from the +5V bus.

JP3

Jumper JP3 connects the +5V bus to the micropower LDO regulator. JP3 can be used to isolate the +5V bus from the micropower LDO regulator.

ON

When connected / ON, +5V from the +5V bus feeds the micropower LDO regulator through a Shottky diode.

OFF

When disconnect / OFF, the micropower LDO regulator does not receive power from the +5V bus.

JP4

Jumper JP4 connects the +5V_USB bus to the micropower LDO regulator. JP4 can be used to isolate (external) +5V USB power from the micropower LDO regulator.

ON

When connected / ON, +5V from the +5V_USB bus feeds the micropower LDO regulator through a Shottky diode.

OFF

When disconnect / OFF, the micropower LDO regulator does not receive power from the +5V_USB bus.

JP5

Jumper JP5 connects the output of the micropower LDO regulator to the VCC bus.

ON

When connected / ON, the micropower LDO regulator feeds the VCC bus.

OFF

When disconnect / OFF, the micropower LDO regulator is disconnected from the VCC bus.

JP6

Jumper JP6 connects the banana jacks J6 and J7 directly to the VCC bus.

WARNING This jumper should be used with care. Putting a voltage above the maximum allowable VCC when JP6 is ON will damage the Flight MCU.

ON

When connected / ON, the + / red jack is connected directly to the VCC bus.

OFF

When disconnect / OFF, the + / red jack is disconnected from the VCC bus.

JP7

Jumper JP7 connects an indicator LED to the +5V bus.

ON

When connected / ON, the indicator LED will illuminate when the +5V bus is active.

OFF

When disconnect / OFF, the indicator LED will not illuminate.

JP8

Jumper JP8 connects a indicator LED to the VCC bus.

ON

When connected / ON, the indicator LED will illuminate when the VCC bus is active.

OFF

When disconnect / OFF, the indicator LED will not illuminate.

JP9

Jumper JP9 connects the VCC bus to the VCC_MCU bus.

ON

When connected / ON, the VCC_MCU bus (which feeds the Flight MCU, among others) will be fed by the VCC bus.

OFF

When disconnect / OFF, the VCC_MCU bus is unpowered.

JP10

Jumper JP10 enables VCC_MCU bus power to the on-board MAX3221 RS-232 transceiver.

ON

When connected / ON, the MAX3221 transceiver is powered (ON).

OFF

When disconnect / OFF, the MAX3221 transceiver is unpowered (OFF).

JP11

Jumper JP11 connects the +5V bus to the VCC bus. It is intended solely for future Flight MCUs that operate at +5V.

WARNING This jumper should be used with care. Connecting JP11 will damage any Flight MCU that is not rated for operation at +5V. It may also cause other damage.

ON

When connected / ON, the +5v and vcc busses are connected.

OFF

When disconnect / OFF, the +5v and vcc busses are isolated.

JP12

Jumper JP12 selects how the MAX3221 RS-232 transceiver is connected to the flight MCU.

Note JP12's pin 1 is at the lower left, when viewing the Development Board with its text oriented horizontally. Similarly, pin 2 is at the upper left.

1-2 (only)

When pins 1 and 2 are connected, the Flight MCU's USART0 is configured for loopback. The MAX3221 is isolated from any other circuitry.

3-4 (only)

When pins 3 and 4 are connected, the MAX3221 is configured for external loopback. The Flight MCU's USART0 is isolated from the MAX3221.

1-2, 3-4

When pins 1 and 2 are connected, and pins 3 and 4 are connected, both the Flight MCU's USART0 and the MAX3221 are configured for loopback.

1-3, 2-4

When pins 1 and 3 are connected, and pins 2 and 4 are connected, the Flight MCU's USART0 is connected directly to the MAX3221.

WARNING Rev A and A1 Development Boards do not include a resistor between the Flight MCU's USART0 receiver pin (URXD0 / P3.5, pin 33) and the MAX3221's receiver output pin (ROUT, pin 9). Therefore care must be taken to avoid enabling the P3.5 pin as an output when JP12's pins 2 and 4 are connected.

JP13

Jumper JP13 selects the operational modes of the MAX3221.

1-2

When pins 1 and 2 are connected, the MAX3221's -INVALID output signal is available on pin 1.

3-4

When pins 3 and 4 are connected, the MAX3221 is forced OFF.

5-6

When pins 5 and 6 are connected, the MAX3221 is forced ON.

7-8

When pins 7 and 8 are connected, the MAX3221 is disabled.

JP14

Jumper JP14 selects the output voltage range for the USB-to-serial converter's I/O pin

WARNING the +5V selection should only be used with +5V-tolerant Flight MCUs.

1-2

When pins 1 and 2 are connected, the USB-to-serial converter's inputs and outputs operate on a +3.3V (nominal) rail.

2-3

When pins 2 and 3 are connected, the USB-to-serial converter's inputs and outputs operate on a +5V (nominal) rail.

JP15

Jumper JP15 connects an indicator LED to the +5V_SW bus.

ON

When connected / ON, the indicator LED will illuminate when the +5V_SW bus is active.

OFF

When disconnect / OFF, the indicator LED will not illuminate.

JP16

Jumper JP16 connects the VCC signal on the Development Board and Flight Module to the VCC_SYS bus. It is intended for the optional isolation of the Flight Module's VCC from VCC_SYS on the bus.

ON

When connected / ON, the VCC and VCC_SYS busses are connected.

OFF

When disconnect / OFF, the VCC and VCC_SYS busses are isolated.

Using the Jumpers

The jumpers are provided on the Development Board to isolate parts of the circuitry, primarily for current measurements. A few examples are given below.

Measuring Quiescent Current Consumption (no Flight MCU)

The quiescent current consumption of the CubeSat Kit's Development Board can be easily measured.

1. Remove the Flight MCU header board.
2. Remove the U1, U2 and U3 buffers from their sockets.

Note Ensure that the proper chips are re-inserted into the U1, U2 and U3 sockets. The chip types ('LVC and 'AHCT families) are not interchangeable.

2. Configure the jumpers as follows:

Jumper	Setting	✓
JP1	OFF	
JP2	ON	
JP3	ON	
JP4	OFF	
JP5	ON	
JP6	OFF	
JP7	OFF	
JP8	OFF	
JP9	ON	
JP10	OFF	
JP11	OFF	
JP12	3-4	
JP13	n/a	
JP14	2-3	

Table 7: Jumper Settings for Measuring Quiescent Current Consumption of Development Board for +3.3V Flight MCUs

3. Apply +5V power at J1. You may need to make a special cable to be able to measure the current drawn.

You should measure around 25 μ A (0.000025A). This represents the current draw of the LDO micropower regulator, MCU reset circuit, and leakage in the level-shifting circuits.

Note U1-U3 must be removed for this test because some of their inputs are floating without a Flight MCU or transceiver present, and will therefore draw appreciable current ($> 1\text{mA}$).

Measuring Operating Current Consumption (with Flight MCU)

Repeat the above steps, but leave U1-U3 installed, and insert a programmed Flight MCU (e.g. with FM430 test/demo software) and a transceiver. Typical current consumption (no LEDs illuminated) for an MSP430 is on the order of 1mA. The test/demo software allows you to shut the processor down into LPM4 mode to verify quiescent current consumption.

Circuit Description

Please refer to the CubeSat Kit schematics while reviewing this section.

Note The Development Board and Flight Module share the same circuitry. The Development Board has additional development and debugging features that are omitted from the Flight Module.

The descriptions and reference designators below are for the Development Board.

Overview

All of the I/O pins, as well as some additional pins, of the Flight MCU microcontroller are connected to the CubeSat System Bus. Power (provided from elsewhere in the CubeSat) is regulated (if required) to meet the MCU's voltage requirements. Power-switching and level-shifting are implemented as necessary. A reset supervisor is employed on the MCU's power bus. A bus-powered⁶ USB interface is provided, with isolation between it and the MCU. Provisions for a transceiver are also provided, again with isolation between it and the MCU. Voltage-level shifting and power switching are provided where necessary. Remove-Before-Flight and Launch switches are also provided.

Flight MCU

The Flight MCU (on H6), a single-chip, ultra-low-power microcontroller with 48 I/O pins, is connected to the CubeSat System Bus connectors (H1, H2). A few of the MCU's I/O pins are dedicated or semi-dedicated to interfacing with and/or controlling other subsystems.

⁶ I.e. the USB system is powered by the +5V that is provided by the USB cable.

Flight MCU Pin(s)	Availability on MSP430-based Designs
P1[0..6]	Free to user.
P1.7	Dedicated to control of USB interface, i.e. normally a digital <i>output</i> . May be used as a digital <i>input</i> to sense whether VCC_IO is present.
P2[0..7]	Free to user.
P3[0..3]	Free to user.
P3[3..0]	For use with on-board SD/MMC mass memory interface (SPI mode) and I2C peripherals.
P3.4	Free to user on Flight Module. On Development Board, can be connected to on-board RS-232 receiver.
P3.5	Free to user on Flight Module. On Development Board, can be connected to on-board RS-232 transmitter.
P3.6	Semi-dedicated as MCU transmit data to USB and transceiver interfaces. Can be used in any other way when neither USB nor transceiver interface is active.
P3.7	Semi-dedicated as MCU receive data from USB and transceiver interfaces. Can be used in any other way when neither USB nor transceiver interface is active.
P4[0..5]	Free to user.
P4.5	Dedicated to controlling VCC_CARD power for SD/MMC interface.
P4.6	Dedicated to controlling +5V_SW power.
P4.7	Free to user.
P5[0..7]	Free to user.
P6[0..5]	Semi-dedicated to USB and transceiver control interfaces. When either the USB or transceiver interface is active, these pins map to the following digital I/O functions (DTE/DCE where applicable): P6.0: -RTS/-CTS P6.1 -DTR/-DSR P6.2 -PWE/-DCD P6.3 -CTS/-RTS P6.4 -RI/-DTR P6.5 -RST/-RST When neither the USB nor the transceiver interface is active, then these pins are free for any purpose.
P6.6	Dedicated to control of transceiver interface.
P6.7	Free to user.

Table 8: Flight MCU I/O Pin Usage

From Table 8 we see that of the Flight MCU's 48 I/O pins, only 3 are permanently dedicated to on-board subsystems. The Flight MCU's UARTs can also interface with other off-board serial devices as long as those devices can be selected independently of the on-board USB and transceiver.

Note On the Development Board, the Flight MCU is mounted on a separate PCB and connects to the Development Board via four headers. This allows the use of different Flight MCUs on the Development Board.

Each Flight Module has its MCU soldered directly on it. There are dedicated Flight Modules for each type of supported Flight MCU.

Clock Sources

The Flight MCU has multiple clock options, which are normally user-configured by stuffing the appropriate crystals (x1-x4) and capacitors, where required.

JTAG, etc.

Each Flight MCU has a programming and debugging connector (J2) for use with standard development tools.

Power

There are two main power busses on the Development Board -- +5V and VCC. VCC_IO, VCC_SYS, +5V_USB and +5V_SW are also present. GND (ground, i.e. 0V) is common across all of the circuitry.

+5V

+5V is connected directly to the PC/104 bus connectors (H3, H4) and is also available on the CubeSat System Bus connectors (H1, H2).

Connector J1 is *directly* connected to +5V, and therefore can be used to supply +5V to the CubeSat from an external power source *regardless of the status of the Remove-Before-Flight and Launch switches.*

+5V_SW

+5V_SW is controlled by the Flight MCU, and provides +5V power on demand to the transceiver. +5V_SW is available on CubeSat System Bus connector H1.

+5V_USB

+5V_USB is derived directly from the USB connector, and is available on CubeSat System Bus connector H1.

VCC

vcc is normally generated on the Development Board from +5V via an ultra-low-quiescent-current low-dropout (LDO) regulator (U5). The LDO regulator's output is set to the desired VCC. VCC's value is chosen based on the Flight MCU. VCC is available on the CubeSat System Bus connector H2. The regulator's output can be disabled by taking OFF_VCC (available on CubeSat System Bus connector H1) high (i.e. to vcc).

The nominal vcc voltage is +3.3V.

VCC_IO

This voltage is generated by the serial-to-USB converter and powers the interface between the Flight MCU and the serial-to-USB converter.

vcc_io is either +3.3V or +5V, depending on the Flight MCU.

Note The USB specification stipulates that a maximum of 500mA be drawn by an USB device.

VCC_SYS

This voltage is present on the CubeSat Kit Bus. It can be connected directly to vcc. If isolated from vcc, it can be used to provide a secondary voltage to other modules connected to the CubeSat Kit Bus.

When connected to vcc, vcc_sys is +3.3V. If not connected, it can be +3.3V or it can be used as a separate power bus with a different voltage.

GND

A star-grounding scheme is used at the Flight MCU's analog and digital ground pins to minimize noise.

Power-Switching

+5V power to the transceiver is controlled by the Flight MCU via a P-channel MOSFET.

Level-Shifting

Logic-level voltage-shifting of individual signals is employed via N-channel MOSFETs wherever signals generated on the VCC rail must control devices on the +5V rail.

Logic-level shifting of multiple signals is accomplished with 'AHCT and 'LVC family logic.

Reset

An on-board Reset Supervisor (U4) is provided to externally reset (-RST/NMI) the Flight MCU should its power drop below a predetermined setpoint. An external reset signal (-RESET) is available on the CubeSat System Bus connector.

An alternate Reset Supervisor (U9) can be fitted.

USB

A serial-to-USB 1.0⁷ interface utilizing FTDI's FT232BM is provided. This interface is powered by the USB host to which it is connected (e.g. a laptop PC) and *draws no power from the CubeSat*. The MCU sees the serial-to-USB converter as Data Terminal Equipment (DTE).

The serial-to-USB converter (on H7) is isolated from the Flight MCU bus via the buffer U1. When the serial-to-USB converter is unpowered, U1 is in a high-impedance state. When the serial-to-USB converter is powered, VCC_IO powers U1. Normally, the Flight MCU's P1.7 (pulled high to VCC_IO) is configured as an input. To connect the Flight MCU to the serial-to-USB converter, the Flight MCU must drive P1.7 LOW while U1 is powered. Resistors R1-R4 are provided to avoid overcurrent damage if Flight MCU pins P3.7 and P6[0..2] are inadvertently configured as outputs when the interface is enabled. Resistors R5-R8 are provided to avoid overcurrent damage if the FT232BM's TXD, -RTS and -RI pins are inadvertently configured as outputs when bit-bang mode is selected.

The Flight MCU's interface to the USB subsystem is outlined in Table 9:

⁷ USB 2.0-compatible.

Flight MCU Pin	Associated USB Signal Name	Description	Polarity
P1.7	-OE_USB	Enables the USB interface when LOW (0V) AND the USB interface is active.	Active LOW
P3.7	TXD_USB	USB Transmit Data, i.e. serial data from USB to Flight MCU.	Active HIGH
P3.6	RXD_USB	USB Receive Data, i.e. serial data from the Flight MCU to the USB.	Active HIGH
P6.0	-RTS_USB	USB's Request-to-Send output.	Active LOW
P6.1	-DTR_USB	USB's Data Transmit Ready output.	Active LOW
P6.2	-PWE_USB	USB's -POWEREN output.	Active LOW
P6.3	-CTS_USB	USB's Clear-to-Send input.	Active LOW
P6.4	-RI_USB	USB's Ring Indicator input.	Active LOW
P6.5	-RST_USB	USB's Reset input.	Active LOW

Table 9: Flight MCU to USB Interface Signals

Bit-Bang Mode

The USB interface chip's bit-bang mode is supported. In this mode, data can be read and written as parallel data on the FT232BM's serial I/O pins, with the following restrictions:

Serial I/O Pin	Bit-Bang Pin	Bit-Bang Function(s) Supported
TXD	Data0	Output only
RXD	Data1	Input only
-RTS	Data2	Output only
-CTS	Data3	Input only
-DTR	Data4	Output only
-DSR	Data5	Not supported
-DCD	Data6	Not supported
-RI	Data7	Input only

Table 10: FT232BM Bit-Bang Mode Pin Functions

The output-only and input-only restrictions arise because U1 is not a bidirectional device, and not all of the FT232BM's 8 bit-bang pins are connected through U1 to the MCU.

MHX Transceiver

An interface to accept an off-the-shelf 2.4GHz Spread-Spectrum transceiver is provided or any other radio with the same connector footprint.. This interface is powered by +5V and *may draw substantial power from the CubeSat*. The Flight MCU sees the transceiver as Data Communications Equipment (DCE).

The transceiver (H5) is isolated from the Flight MCU bus via the buffers U2 and U3. When the Flight MCU wishes to transmit or receive, it enables the transceiver interface by taking P6.6 LOW. This powers up the transceiver, as well as U3. Resistors R9-R12 are provided to avoid overcurrent damage if Flight MCU pins P3.7 and P6[0..2] are inadvertently configured as outputs when the interface is enabled.

The Flight MCU's interface to the transceiver subsystem is outlined in Table 11:

Flight MCU Pin	Associated Transceiver Signal Name	Description	Polarity
P6.6	-OE_MHX	Enables the transceiver interface when LOW (0V).	Active LOW
P3.7	RXD_MHX	Transceiver Receive Data, i.e. serial data from transceiver to Flight MCU.	Active HIGH
P3.6	TXD_MHX	Transceiver Transmit Data, i.e. serial data from the Flight MCU to the Transceiver.	Active HIGH
P6.0	-CTS_MHX	Transceiver Clear-to-Send output.	Active LOW
P6.1	-DSR_MHX	Transceiver Data Set Ready output.	Active LOW
P6.2	-DCD_MHX	Transceiver Data Carrier Detect output.	Active LOW
P6.3	-RTS_MHX	Transceiver Request-to-Send input.	Active LOW
P6.4	-DTR_MHX	Transceiver Data Terminal Ready input.	Active LOW
P6.5	-RST_MHX	Transceiver Reset input.	Active LOW

Table 11: Flight MCU to Transceiver Interface Signals

External Control

The transceiver can be controlled externally, i.e. by a processor other than the Flight MCU. This is done by applying +5V to the +5V_SW terminal on the CubeSat System Bus connector H1. Most of the transceiver's control signals are available on the CubeSat System Bus connector H1.

Warning Simultaneous external control of the transceiver and Flight MCU enabling of the transceiver interface must be avoided! It is recommended that the interface and +5V_SW circuitry be removed if you intend to control the transceiver externally via the CubeSat System Bus connector H2.

Remove-Before-Flight and Launch Switches

Two separate, high-reliability switches are provided for the CubeSat's Remove-Before-Flight (RBF) and Launch switch specifications. Additionally, a dedicated pair of terminals (ZP1 & ZP2) are provided for a GND connection.

The RBF Switch C and NO terminals are connected when the CubeSat's RBF pin is in place. When the RBF pin is removed, the RBF switch C and NC terminals are connected.

The Launch Switch C and NO terminals are connected when the CubeSat is placed into the CubeSat launcher. When the CubeSat is released from the launcher, the Launch switch C and NC terminals are connected.

Direct Wiring

All of the switch contacts (C/common, NC/normally closed and NO/normally open) are available should the user decided to wire directly to the switches.

Wiring via the CubeSat System Bus

4 of the 6 switch terminals are provided on the CubeSat System Bus connector H2, and implement 4 of the 5 distinct terminals of two serially-connected switches. The following CubeSat global power disconnect schemes are examples of what can be implemented, assuming a unipolar power supply (i.e. voltage source) where the "-" terminal is 0V and the "+" terminal is greater than 0V, e.g. +5V.

Description	Implementation
Ground-Lift with RBF Switch only	<ul style="list-style-type: none"> CubeSat System Bus Connector H2: Connect CubeSat power supply "-" to LS_NC, and "+" to power distribution circuitry.
Ground-Lift with RBF and Launch Switches	<ul style="list-style-type: none"> Flight Module / Development Board: Connect ZP1 to ZP2 CubeSat System Bus Connector H2: Connect CubeSat power supply "-" to LS_NC, and "+" to power distribution circuitry.
Power Interruption with RBF Switch only	<ul style="list-style-type: none"> CubeSat System Bus Connector H2: Connect CubeSat power supply "-" to RBF_C, and "+" to RBF_NC.
Power Interruption with RBF and Launch Switches	<ul style="list-style-type: none"> CubeSat System Bus Connector H2: Connect CubeSat power supply "-" to RBF_C, and "+" to LS_NC.

Table 12: CubeSat Global Power Disconnect Schemes

Table 12 illustrates how global power disconnect can be implemented without any discrete wires beyond those that connect the RBF and Launch switches directly to the Flight MCU.

Tip In a ground-lift configuration, the RBF and Launch switch NO terminals can be used to hold a power supply pin (e.g. the "+" terminal of discharged batteries) at GND potential.

CubeSat System Bus

The CubeSat System Bus (on connectors H1 and H2) provide a means of connecting the Flight MCU's 48 I/O pins, and additional Flight MCU pins, to user circuitry elsewhere in the CubeSat. The CubeSat System Bus connector pinout is outlined below:

Pin(s)	Signal Name	Type	Logic Level	Description
1-8	P5[7..0]	I/O	VCC	Flight MCU Port P5
9-16	P4[7..0]	I/O	VCC	Flight MCU Port P4
17-24	P3[7..0]	I/O	VCC	Flight MCU Port P3
25	USER0	-	-	Defined by user.
26	VREF+	O	VCC	Flight MCU internal A/D reference
27	USER1	-	-	Defined by user
28	VEREF+	I	VCC	Flight MCU external + reference
29	-RESET	I	VCC	External -RESET to Reset Supervisor
30	VREF-	I	VCC	Flight MCU external - reference
31	OFF_VCC	I	VCC	External disable of on-board VCC regulator
32	+5V_USB	PWR		From USB Interface. Must not exceed 500mA.
33	+5V_SW	PWR		Normally from +5V, under Flight MCU control
34	-RST_MHX	I	+5V_SW	Transceiver Reset
35	-CTS_MHX	O	+5V_SW	Transceiver Clear-to-Send
36	-RTS_MHX	I	+5V_SW	Transceiver Request-to-Send
37	-DSR_MHX	O	+5V_SW	Transceiver Data Set Ready
38	-DTR_MHX	I	+5V_SW	Transceiver Data Terminal Ready
39	-TXD_MHX	I	+5V_SW	Transceiver Transmit Data
40	-RXD_MHX	O	+5V_SW	Transceiver Receive Data

Table 13: CubeSat System Bus Connector H1

Pin(s)	Signal Name	Type	Logic Level	Description
1-8	P6[7..0]	I/O	VCC	Flight MCU Port P6
9-16	P1[7..0]	I/O	VCC	Flight MCU Port P1
17-24	P2[7..0]	I/O	VCC	Flight MCU Port P2
25,26	+5V	PWR		PC/104 Bus +5V
27,28	VCC_SYS	PWR		Flight Module power if VCC connected to VCC_SYS via JP16
29-32	GND	PWR		System GND
33, 34	LS_NC	I/O		Launch Switch Normally Closed Terminal
35,36	LS_NO	I/O		Launch Switch Normally Open Terminal
37,38	RBF_NC	I/O		Remove-Before-Flight Switch Normally Closed Terminal
39,40	RBF_C	I/O		Remove-Before-Flight Switch Common Terminal

Table 14: CubeSat System Bus Connector H2

PC/104 Bus

As detailed in *PC/104 Compatibility*, only +5V and GND are available to from the PC/104 bus. Therefore only a 32-pin subset of the total of 104 PC/104 connector pins are implemented.

Additional Components and Circuitry

Bypass Capacitors

Bypass capacitors across each power supply are provided.

Test Points

Test points for signals of interest are provided.

Additional Features of the Development Board

Power

The Development Board accepts 6-24V dc input as a source for system power via an additional LDO regulator with fixed +5V output. 6-24V dc can be applied via a 2.1 or 2.5mm dc power plug

(center is + polarity), or via laboratory banana jacks (GND/- is black, + is red).

Each major power connection can be interrupted by means of a jumper. This allows the user to isolate any part of the power system from another, which is especially useful when measuring currents.

Reset

A manual Flight MCU Reset pushbutton switch is provided.

Indicators

LED indicators are provided for +5V, +5V_SW, VCC, USB Rx/Tx status and transceiver status.

USB

The Development Board uses a serial-to-USB converter. The USB circuitry is bus-powered, and draws no current from the CubeSat Kit when the USB cable is disconnected.

RS-232

A micro-power RS-232 transceiver (configured as DTE, for software (XON/XOFF) handshaking) is provided. It can be selectively enabled or disabled.

Prototyping Area

The Development Board includes a 26x30 0.100" grid for use as a prototyping area. Additionally, two 1x30 0.100" columns of GND and two 1x15 / 1x15 0.100" columns of +5V / VCC power are provided.

PC/104 Compatibility

The PC/104 standard provides electrical and mechanical specifications for embedded systems using the PC and PC/AT (ISA) bus standard in a custom form factor. PC/104 cards are popular in industrial control and monitoring, and provide an COTS means of obtaining considerable computing and I/O power in a compact form factor.

Mechanical Compatibility

The CubeSat Kit is designed to accept stackthrough PC/104 cards above the Flight Module. The restrictions on the card slots are listed in Table 4.

25mm (1") M3 threaded spacers are normally used between adjacent slots. If a transceiver is not fitted on the Flight Module (Slot 0), 15mm spacers⁸ should be used between Slot 0 and Slot 1. This configuration leaves room for a low-profile user module in Slot 1, but not enough for a PC/104 module in that slot.

Connectors

The PC/104 connectors on the Flight Module are of the non-stacking type. They are either 15mm or 25mm tall, depending on whether a transceiver is fitted to the Flight Module.

All other PC/104 connectors are of the conventional, stackthrough type.

Note Only J1 pins 1-4 and 29-32, and J2 pins 0-3 and 16-19 are implemented on the Flight Module. Therefore, to connect J1 or J2 to a PC/104 module in Slot 1, 2x4 headers (instead of 2x32 and 2x20, respectively) are used.

Voltages

Warning The MSP430 on the Flight Module is a +3.3V only MCU. Therefore level-shifting circuitry must be used when

⁸ And taller PC/104 bus connectors.

interfacing this MCU to the PC/104 bus, which runs at a nominal +5V. Connecting +5V to any pin on the MSP430 will irreparably damage the device!

Texas Instruments and other manufacturers have logic families specifically designed to translate +3.3V to +5V, sometimes bidirectionally.

Electrical Compatibility

The ISA bus specification, around which PC/104 is built, is designed fundamentally for *microprocessors*, not *microcontrollers (MCUs)*. I.e. it is designed for use with processors that have external data and address busses, and the associated control signals.

The ISA bus is not well-suited for use with microcontrollers. Interfacing a single-chip microcontroller to the ISA bus usually involves a considerable amount of "glue" logic. Additionally, the speeds⁹ of processors on the ISA bus often greatly exceed those of popular microcontrollers, further complicating the interface.

Interfacing to PC/104

For the reasons above, the CubeSat Kit's Flight Module makes no attempt to interface to the PC/104 bus, save for +5V and GND. *We recommend that interfacing the Flight MCU to the PC/104 bus be done on the user module in Slot 1.* Since all of the Flight Module's I/O pins are available on the CubeSat Bus Connectors, any interface between the PC/104 bus and the Flight MCU can be implemented.

For example, if you wanted to implement an 8-bit data port with handshaking between the PC/104 bus and the Flight MCU, you would probably use one of the Flight MCU's 8-bit I/O ports, along with a few dedicated handshaking lines. This circuitry would reside on the Slot 1 User Module, which connects to the Flight Module in Slot 0 via the CubeSat Bus connector, and to the PC/104 bus of Slots 2-4 via the PC/104 bus connectors.

⁹ E.g. a 50MHz 486-class processor.

PC/104-Plus Compatibility

The CubeSat Kit does not directly support the PC/104-Plus (32-bit) standard. However, PC/104-Plus modules can be mounted in any slot that normally accepts PC/104 modules, as long as there is no mechanical interference between the PC/104-Plus module's 32-bit connectors and the rest of the system.

Frequently Asked Questions (FAQ)

General

What is the CubeSat Kit designed to do?

The CubeSat Kit is designed for low mass, high strength, maximum useable surface area, minimum power consumption and maximum configurability while conforming to the CubeSat specifications.

What do I have to add to the CubeSat Kit to turn it into a functional satellite that's ready for launch?

At a minimum, you'll need to add a power source (i.e. batteries, solar cells, etc.), and your payload / experiment. You'll want to add a transceiver and an antenna if you plan to communicate with your CubeSat. Plus, you'll need to program the Flight MCU to run your CubeSat and handle communications, etc.

Why doesn't the CubeSat kit include an antenna / solar cells / ...?

The design of items like antennas and power-supplies is very mission-oriented, and should be tailored to each individual CubeSat. The CubeSat Kit is a general-purpose kit, and is designed to satisfy the basic requirements of the CubeSat specifications.

With the CubeSat Kit, you don't have to worry about building a sturdy yet light enclosure, adding Remove-Before-Flight and Launch Switches, creating a working connector scheme, picking a microcontroller, etc. We've done all of that for you!

Does the CubeSat Kit include a radio (transceiver)?

No, but you can buy one from Microhard Systems (<http://www.microhardcorp.com/>) off-the shelf, plug it into the Flight Module, add an antenna and you're ready to begin sending and receiving.

Alternately, you can use other transceivers with adapters available from Pumpkin, or you can design your own transceiver as long as it has a compatible connector footprint and can use +5V as the source of its power.

I prefer to use / design my own radio. Will that work in the CubeSat Kit?

Yes. The CubeSat Kit can be configured in various ways. You can put your own radio in the CubeSat Kit, either in the dedicated radio slot on the Flight Module, or on a user module.

Do I have to create my own Printed Circuit Boards (PCBs) in order to use this CubeSat Kit?

No. For simple designs, you can use the Flight Module's powerful MCU as your primary controller. You can put your own electronics (serial EEPROMs, sensors, power supply, connectors, etc.) on a CubeSat Kit Protoboard and connect them via the CubeSat System Bus connectors.

Sophisticated users with complex designs will want to build their own modules on custom PCBs. Again, these will connect to the Flight MCU via the CubeSat System Bus connectors. User modules can also connect to the PC/104 bus, or even the PC/104-Plus bus.

Why is the PCB mounting scheme of the CubeSat Kit designed around the PC/104 mechanical specifications?

First, the PC/104 specification has a simple, pass-through connector scheme that is well-suited to the tight confines of the CubeSat. The CubeSat System Bus connector is the same as the standard PC/104 stackthrough 40-pin connector, a well-established industry standard.

Second, many potential CubeSat developers want to run sophisticated applications on their CubeSats that they can first develop on PCs. By accommodating +5V-only PC/104 modules, the CubeSat Kit supports x86-class single-board computers (SBCs) in the PC/104 form factor like the Diamond Systems (<http://www.diamondsystems.com/>) Prometheus SBC, which was used in the successful QuakeSat project

(<http://www.quakefinder.com/quakesat.htm>). Naturally, other PC/104 modules can also be used in the CubeSat Kit.

Third, the mechanical layout of PC/104 modules leaves a considerable percentage of the total PCB area available for circuitry.

What equipment do I need to program the Flight MCU?

All you need beyond the CubeSat kit is a PC and a compiler / Integrated Development Environment (IDE).

The CubeSat Kit contains all of the hardware required to connect a PC to the Development Board and Flight MCUs for downloading, programming and debugging.

Each CubeSat Kit also includes the Salvo RTOS for the MCU on the Development Board and Flight Module. You will need supported a compiler to develop software for this MCU. Low-cost compilers and IDEs are commercially available. See the Pumpkin website (<http://www.pumpkininc.com/>) for more information.

What's the difference between the Development Board and the Flight Module?

The Development Board is on a much larger PCB to facilitate access to the various systems on-board. It also includes provisions for multiple power supply sources, and jumpers to isolate parts on the system. It also includes some additional circuitry not available on the Flight Module (e.g. indicator LEDs and an RS-232 port). Electrically, the Flight Module is a subset of the Development Board.

Assembly / Mechanical

What is the CubeSat Kit structure made of?

The CubeSat Kit is made from sheet aluminum, in thicknesses appropriate for each individual part. All external fasteners are made from stainless steel.

Is the CubeSat Kit an inch or metric design?

All of the user-serviceable fasteners are metric except those that hold the RBF and Launch switches. All relevant dimensions are presented in metric units.

Is the CubeSat Kit structure hard-anodized?

Yes, the rails and feet are hard-anodized to prevent galling when in contact with the CubeSat launcher. The rest of the structure is alodined, which is an electrically-conductive surface finish.

Why is there an oval cutout on the front face of the CubeSat Kit?

This cutout enables the MHX transceiver to fit within the confines of the CubeSat's 10x10x10 cm size. If you use the MHX transceiver, you'll find that this cutout leaves enough room to attach your antenna cable to the MHX transceiver. If you don't use the MHX transceiver, you can put solar cells over the cutout, run other wires in and out of the CubeSat there, etc.

It doesn't look like I can fit all of my payload into a 10x10x10cm (1U) CubeSat Kit. Are larger CubeSat Kits available?

Yes, 1½U, 2U and 3U CubeSat Kits are available. They are identical to the 10x10x10cm (1U) CubeSat Kit except for their chassis, which are correspondingly longer.

Environment

What temperature range is the CubeSat Kit designed for?

All of the parts in the CubeSat kit that are destined for space operate over the -40 to +85 C industrial temperature range.

What kinds of glues and/or epoxies are used in the CubeSat Kit?

All of the components in the CubeSat Kit are permanently riveted, positively fastened with machine screws, or soldered to the Flight Module. Users may employ space-grade adhesives are used to lock certain fasteners in place.

What kind of wiring does the CubeSat Kit have?

The only wires in the CubeSat Kit connect the Remove-Before-Flight and Launch switches to the Flight Module or to user circuitry. All other inter-board interconnects are done with 0.100" spacing headers.

Payload

My CubeSat payload is very flat. Can I put it on a PC/104 card?

Sure. If you design your payload to fit inside a PC/104 module's form factor, you can stack it along with the other user modules and PC/104 modules in your CubeSat.

My CubeSat payload measures 5x5x5cm. Can the CubeSat Kit accommodate it?

Yes. With only the Flight MCU in place, there's plenty of room for large payloads. You may want to consider mounting any user modules against the side walls of the CubeSat Kit.

How can I run wires from a module to the top surface of the CubeSat Kit (the one where the Flight Module is mounted)?

There is a 4.7mm slot between the front edge of the Flight Module and the CubeSat Kit inner wall. There is a 3mm slot between the rear edge and the CubeSat Kit inner wall. To reach that surface from inside the CubeSat (e.g. to wire solar cells), route your wires through these slots.

The allowable height on Slot 5 is only 6mm. What is Slot 5 good for?

Slot 5 is immediately below the CubeSat Kit's bottom cover. Therefore it's an ideal location to place sensors that must be exposed to space, e.g. a miniature camera lens. Just cut a hole in the bottom cover that's large enough for the camera lens to pass through, and not violate the CubeSat's allowable external dimensions.

Electronics

How much power does the Flight MCU take?

The Flight MCU uses an ultra-low-power microcontroller. At full speed,¹⁰ the entire Flight Module should consume no more than 20mA @ +3.3V (66mW). By taking advantage of the MSP430's power-saving design and the event-driven Salvo RTOS, the average current should drop to well below 1mA (3.3mW).

Why is a linear regulator used to generate VCC? I thought switchers are more efficient.

A low-dropout (LDO) linear regulator was chosen for this application primarily because it requires fewer parts (thus enhancing reliability and reducing weight) than most switchers, and the Flight MCU's power consumption is so low that the overall system power savings would be negligible with a switcher.

If your CubeSat already generates a suitable vcc, you should remove the regulator on the Flight Module and feed it vcc via the CubeSat System Bus connector.

What kinds of electronic components are used in the CubeSat Kit?

Primarily small surface-mount components, like 0805 and 1206 passive packages, and SOT-23, TSSOP and TQFP chip packages. With some skill and experience, they can be reliably soldered by hand.

How much current can the Remove-Before-Flight and Launch Switches conduct?

They are each rated for 10A. The same switches are used in all CubeSat Kits, regardless of size.

¹⁰ 7.3728MHz for an MSP430-based Flight Module, does not include power required by the transceiver.

Why are separate signals from the Flight MCU used to enable +5V_SW power and the MHX transceiver interface?

This is done primarily for two reasons: 1) The MHX transceiver takes a relatively long time to power up. The `-ON_+5V` signal allows the Flight MCU to keep the MHX transceiver power on while the interface is disabled and the I/O pins are used for other purposes. 2) For CubeSat Kit configurations that employ the Flight MCU as the main processor, `+5V_SW` can be used as a power supply signal that is under the Flight MCU's control.

Can I leave the Flight MCU on all the time while in orbit?

Theoretically, yes. Its power consumption is so small (especially in its power-saving modes) that you can probably leave it on all the time.

How do I manage power consumption in the CubeSat Kit?

The biggest drain on your power supplies is likely to be your transceiver (radio), especially when transmitting. The Flight MCU can control power to the MHX transceiver, so that it only consumes power when the Flight MCU is ready to transmit data.

Does the CubeSat Kit include a power supply?

A 5V external table-top power supply is included for use with the Development Board and the Flight Module. It is used to power the Development Board, and can also power an assembled CubeSat through the external power connector.

It is up to you to design your own internal power system for your CubeSat. This will normally involve solar cells and/or batteries, and may require outputs at multiple voltages (e.g. +3.3V and +5V). CubeSat power supplies are normally tailored to the CubeSat's payload and processor(s).

I want to run Linux in my CubeSat. Is the CubeSat Kit compatible?

The Flight MCU is much too small to run Linux. However, there are many off-the-shelf PC/104 modules (e.g. <http://www.gumstix.com/>) with processors that are capable of running Linux. So, just pick one and put it in your CubeSat Kit.

I plan on running both a PC/104 SBC and the Flight Module's MCU in a dual-processor configuration. How can I interrupt the Flight MCU from the SBC?

The MSP430 Flight Module accepts the -RESET signal from the CubeSat System Bus. This signal can activate the -RST/NMI signal. The MSP430 Flight MCU can be configured in software to treat the -RST/NMI signal as a non-maskable interrupt.

Are the AHCT and LVC '244 interface chips really necessary?

Yes. Without them, the Flight MCU could be subjected to overvoltages on its inputs, leading to damage. The type of interface chips and the overall circuit topology has been carefully chosen to eliminate any chance of damage to the Flight MCU from the +5V-based USB-to-serial converter and MHX transceiver *in any powered or unpowered state*. Additionally, the interface chips guarantee the correct logic-level signals when the Flight MCU is connected to either interface, and they guarantee zero power consumption.

Why does the Development Board have an RS-232 connector?

To facilitate your CubeSat development. For example, you might decide that the easiest way to interface the Flight MCU to a PC/104 or PC/104-Plus module with an x86-class processor running Linux is via a serial port. This is advantageous, because RS-232 drivers operate at RS-232 voltage levels, which bypasses the issue of +3.3V to +5V translation. So, You could place your PC/104 module on the Development Board and connect its processor to the Flight MCU via this serial port. You would need to eventually design your own RS-232 interface on a user module when you integrate your design into a CubeSat.

The RS-232 driver is not incorporated into the Flight Module because that would unnecessarily constrain the design.

Alternatively, you could use the RS-232 port for `printf()`-style debugging, and simply ignore it when you integrate your design into a CubeSat.

Communications Interfaces (USB and MHX Transceiver)

How can I use the Flight MCU's A/D inputs to sample voltages throughout my CubeSat? They're connected to the USB and MHX transceiver interfaces!

You can use most of the Flight MCU's analog inputs for voltage sampling because the USB-to-serial converter and the MHX transceiver *are normally isolated from the Flight MCU's bus*. When you want to sample, disable the interfaces, configure the I/O pins as analog inputs, and sample. When you want to connect to either the USB-to-serial converter or the MHX transceiver, configure the I/O pins as digital inputs or outputs, and enable one of the interfaces. The I/O pins that enable the interfaces must always be configured as digital inputs or outputs.

A few precautions must be taken for this to work properly. You can either selectively isolate your analog sources from the Flight MCU bus (e.g. by using an analog switch), or you can buffer the analog sources in a manner that's tolerant of being driven by a digital signal appearing at the I/O pin.

Can I use the Flight MCU's second UART to talk to serial devices other than the USB-to-Serial converter and MHX transceiver?

Yes. When neither of these on-board interfaces is enabled, you can talk to other serial devices. You must ensure that when either the USB-to-serial converter or the MHX transceiver is enabled, your other serial devices are disabled (tri-state / hi-Z) on the UART's receive data pin.

Can the Flight MCU talk to both the USB-to-serial converter and the MHX transceiver at the same time?

No. Only one interface should be active at the same time. Control of the interfaces is under the Flight MCU's control. The USB-to-serial converter is envisioned as an "on the ground" communications link, and the MHX transceiver is envisioned as an "in-flight" communications link. Therefore you would not normally need to have both active at any time.

Why don't the data and control signal names for the two interfaces match?

They don't match because one is Data Terminal Equipment (DTE), and the other is Data Communications Equipment (DCE).

What kind of handshaking do the interfaces support?

The USB-to-serial converter interface supports simple hardware handshaking (RTS/CTS), as well as software handshaking (XON/XOFF).

The MHX transceiver supports full hardware handshaking (RTS/CTS, DSR/DTR, DCD), as well as software handshaking.

Can I reset the interfaces?

Yes. Each interface can be reset by the Flight MCU.

Can an external processor interface with the USB-to-serial converter?

No. To move data from an external processor (e.g. a PC/104 SBC) through the USB-to-serial converter will require that the external processor communicate with the Flight MCU serving as an intermediary.

Can an external processor interface with the MHX transceiver?

Yes, directly over the CubeSat System Bus. This requires that the external processor apply +5V power to +5V_SW. All of the MHX transceiver's data and control signals except DCD are available on the CubeSat System Bus connectors.

Can I use the USB port in space?

If your USB cable is long enough ...

How many CubeSat Kits can I connect to a PC via USB?

The number of CubeSat Kits that can be connected via USB is limited solely by the number of USB ports on your PC.

The USB chip uses almost as much power as the Flight MCU! Isn't that wasteful?

The USB interface is designed so that it is only powered when connected to an external host (e.g. a laptop PC). At all other times the USB interface consumes no power.

Why aren't any MHX transceiver status indicators available to the Flight MCU or on the CubeSat System Bus connector?

All of the MHX transceiver's status information can be gleaned by reading from its internal registers. Therefore these signals are unnecessary. They are attached to LEDs on the Development Board as a visual aid.

I prefer to use my own radio. How can I integrate it into the CubeSat Kit?

The simplest approach is probably to package your radio in the same form as the MHX transceiver, so that it can be plugged into the MHX transceiver sockets. You can then choose to control the radio from the Flight MCU, or externally via the CubeSat System Bus. Note that the MHX transceiver socket is supplied with +5V power from +5V_SW.

Can I use the USB-to-serial converter's serial memory chip for purposes other than USB configuration?

No, it is not intended for general-purpose use.

Shouldn't I be concerned with the MHX transceiver's cable sticking out of the side of the CubeSat Kit?

Not really. The MHX transceiver is quite large compared to the CubeSat, and we felt that this was the best installation location for it. The cable is still within the CubeSat specifications regarding items protruding above the CubeSat sides. We recommend you use some mechanical means to ensure that the cable will stay connected to the transceiver. The fact that it is exposed to space is not cause for worry.

PC/104

How PC/104-compatible is the CubeSat Kit?

PC/104 boards that do not extend beyond the primary board dimensions of 90x96mm can be mounted inside the CubeSat. Power (+5V) and ground connections to the Flight Module are provided in the J1 and J2 connectors.

Why are only a few of the PC104 bus pins implemented on the Flight Module?

Because the PC/104 bus is designed for microprocessors and not microcontrollers (like the Flight MCU), it is not easily interfaced to a microcontroller. Therefore, only +5V power and GND are connected from the Flight Module to the PC/104 bus.

When are PC/104 connectors required on the Flight Module?

The 2x4 PC/104 connectors are only required on the Flight Module when there is a PC/104 module in Slot 1, or when there are PC/104 modules in Slot 2 through Slot 4 and you haven't connected the +5V and GND signals on the CubeSat System Bus connectors to the PC/104 connectors in a user "bridge" module.

How many PC/104 cards can I fit in the CubeSat Kit?

You can fit a total of 4 PC/104 cards in the 10x10x10cm CubeSat Kit. They mount directly above the Flight Module.

Can I use a PC/104 prototyping card to build a user module?

Yes. The Diamond Systems (<http://www.diamondsystems.com/>) Proto-104 prototyping card can be used. PC/104 and/or CubeSat System Bus connectors can be soldered to it to mate with a Flight Module.

Can I use off-the-shelf PC/104 modules in the CubeSat Kit?

Yes. Any PC/104 module can be used. If it's a +5V-only module, it will plug right into the module stack. If it requires other voltages, you'll have to provide them, too.

Can I use PC/104-Plus modules in the CubeSat Kit?

Yes. Any PC/104-Plus module can be used.¹¹ The Flight Module only has +5V and GND for 8- or 16-bit PC/104 cards. If your PC/104-Plus module requires other voltages, you'll have to provide them, too.

I plan to use a PC/104 SBC running Linux in my CubeSat, and I'm not sure I want / need the Flight Module. Can I remove it to save weight?

The Flight module performs several functions in addition to being the home of the Flight MCU. The Remove-Before Flight switch and MHX transceiver are mounted to it. Additionally, there is not enough room to mount a PC/104-sized module in Slot 0. Therefore you should probably keep the Flight Module, and consider assigning it another role (perhaps that of a system supervisor or backup processor) outside of the functionality you plan to implement on your Linux SBC.

Why can't I use the MHX transceiver with a PC/104 module in Slot 1?

There isn't enough room. The PC/104-Plus specification calls for approximately 5mm of clearance below any PC/104-Plus card. PC/104 Cards often have components on the underside of the PCB, too. With the MHX transceiver on the Flight Module, there simply isn't enough room to accommodate components on the underside of the module in Slot 1.

To use the MHX transceiver with PC/104 cards, you could design your own user module for Slot 1, and place your PC/104 module in Slot 2 or higher. Or, you could design your own transceiver to plug into the Flight Module – it would require a substantially lower profile than the MHX transceiver.

¹¹ Physical packaging issues dictate that a user module can connect to the PC/104 bus, and to either the PC/104-Plus bus or the CubeSat System Bus, but not both.

Software

What programming background does the CubeSat Kit require?

You should be comfortable programming microcontrollers in C. Some experience with programming paradigms beyond the simple foreground / background loop is helpful.

What kind of software does the CubeSat Kit include?

The Flight MCU comes pre-programmed with a basic "skeleton" application that will get you started. It's based on the Salvo RTOS, to make it easier for users to manage the multitude of things the Flight MCU will be called upon to do. All application source code (in C) is included.

What are the advantages of this RTOS-based software approach?

RTOS-based programming is one of the dominant programming paradigms for embedded programming. The Internet is full of information on this subject. Because Pumpkin's (<http://www.pumpkininc.com/>) Salvo RTOS is an event-driven RTOS, you will be able to minimize power consumption while maximizing functionality in the Flight MCU.

How do I interface to the USB port?

You'll need the CubeSat Kit USB drivers to interface your PC to the CubeSat Kit's USB port. You can use the USB port as a simple terminal interface to the Flight MCU, or you can write your own software in the Flight MCU and/or the host side to do things like serial bootloaders, etc.

Discussion Forums

A series of CubeSat User Forums have been created on the Pumpkin web site for the express purpose of discussing issues that surround the CubeSat kit. Announcements, notices, links to relevant files, etc. will all be posted to the Forums.

To access the forums, choose the Forums link from Pumpkin's home page. New users must register before they are allowed to post new topics or reply to existing ones.

Note We would like *all* discussions regarding the CubeSat kit to take place in the Forums, not via private email.
